



CAREL

CAREL
retail 
sistema

the one solution

I n t e g r a t e d S o l u t i o n & E n e r g y S a v i n g

Integration, energy saving, food quality



CAREL retail sistema

Monitoring and Telemaintenance



PlantVisorPRO
High end supervisory solution



Refrigeration utilities



Refrigerated showcases

Compressor racks



Dedicated solutions
for cold rooms

Maximum performance
and energy saving

The large retail business is a sector with many different requirements, varying specifications and important critical aspects: there is increasing demand for new solutions that go beyond the standard requirement of guaranteeing the correct operation and supervision of the installation.

CAREL retail sistema is the solution that CAREL has developed to respond to the current challenges in this market: a dedicated approach that improves the overall management of the installation and brings savings in energy costs.

CAREL retail sistema can satisfy all requirements for the control, integration and supervision of the different functional areas involved in the generation and delivery of cooling for foodstuffs and the control of room air-conditioning.



In addition, special focus has been placed on reducing energy consumption through the use of innovative technology developed by CAREL.



Control of the cooling systems and observance of the regulations in force is guaranteed by the use of specific standards-compliant solutions and integration of these into just one system.



From the smallest sales outlet to the remote management of a chain of hypermarkets, CAREL is a partner that can offer...

...the one solution

Air-conditioning

Electrical loads



Complete and integrated solution



From monitoring to proactive control

Integration, energy saving, food quality

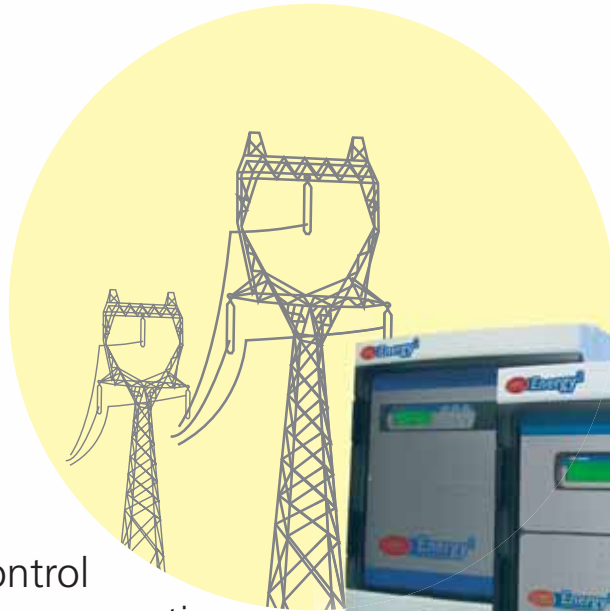

Energy control

Dedicated solutions for the control of electrical loads and energy consumption. Integration of third party monitoring instruments.



Retail operators need to have all the possible information available on the installation, as well as the reciprocal optimisation of all the peripherals.

This need is best provided for by a flexible range of controllers and specific software for each functional area, and this is exactly what CAREL is investing in and pursuing with the CAREL retail sistema.

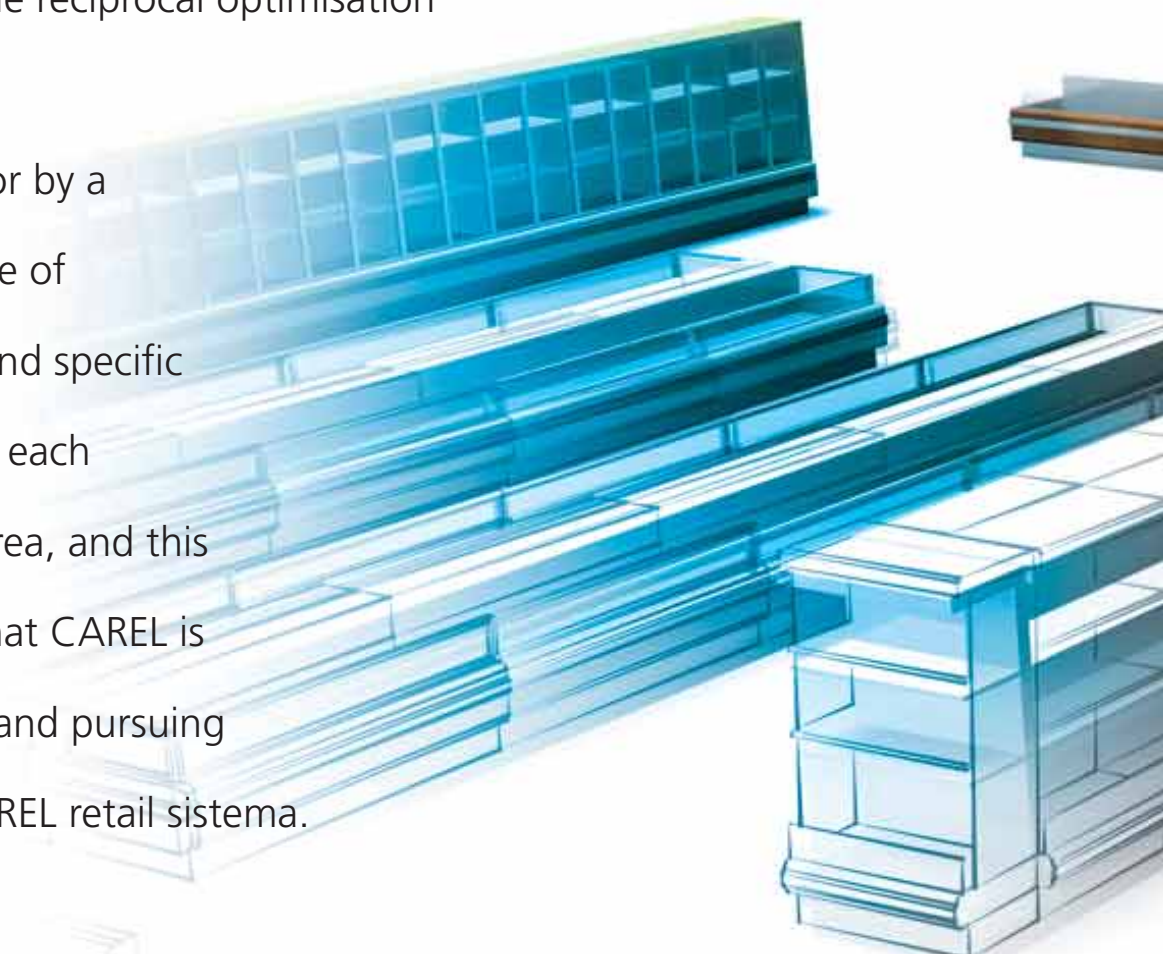

MPXPRO, MasterCase, MasterCella

Up to **25%** savings in energy consumption with E²V valves.

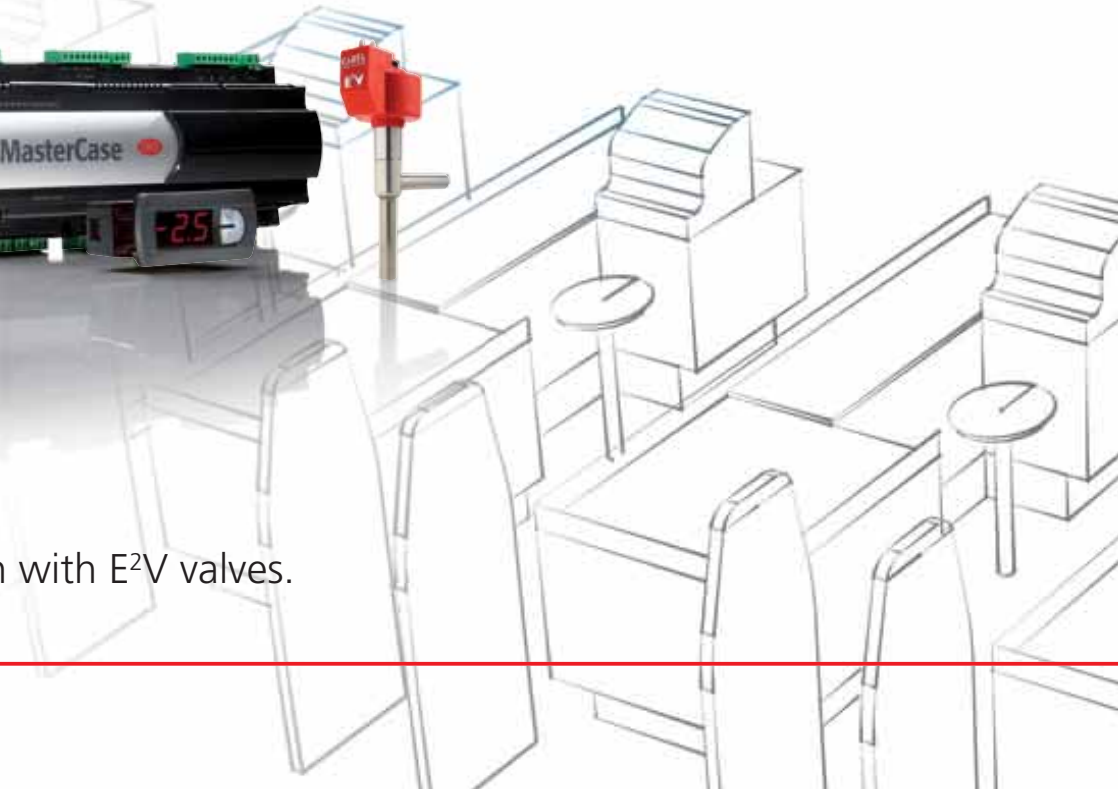

rack Controller, μ Rack,

Energy saving and floating operating pressure.
Maximised efficiency of the E²V valves.
Entry level solutions for small compressors
or programmable solutions for large racks.
Complete configurability.

pCO sistema for AHU, rooftop, chiller units

Total integration and accessibility in
the supervision of the installation.
Complete management of the unit, with control
over both standard and custom functions.



sistema

CAREL re

PlantVisorPRO

Monitoring, supervision, alarms and logs.
Local or remote point-to-point access,
access via the Internet.



Technology and precision for the Retail market

Years of experience in commercial refrigeration, electronic control and supervision have allowed CAREL to acquire the know how required to develop a system specifically dedicated to the retail market:
CAREL retail sistema.

CAREL is and has always been the developer and promoter of advanced **control systems**, both at an individual-unit level, optimising operation, and as regards the **integrated management of complete installations**, with solutions for local and remote access and wired or wireless connectivity.

The company is one of the biggest investors in **research and development** in the sector, and considers this to be a point of distinction in a market that is so focused on innovation.

The many recent developments and innovations in the Retail context include the incredibly successful E²V proportional electronic expansion valve.

By installing an E²V on each refrigeration utility and using CAREL controllers for compressor racks and the PlantVisor supervision system, very significant **energy savings** can be achieved in both **refrigeration** and **air-conditioning**, as highlighted by the case studies completed on extensive field trials.

The consequent reduction in polluting emissions is one further “side effect” that all leading retail and industrial businesses are striving for: today, being a **“green company”** is more a duty than a luxury.



driven by

CAREL

Air-conditioning Case Study

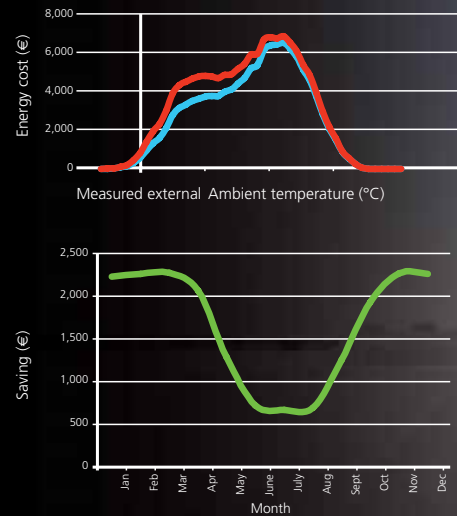
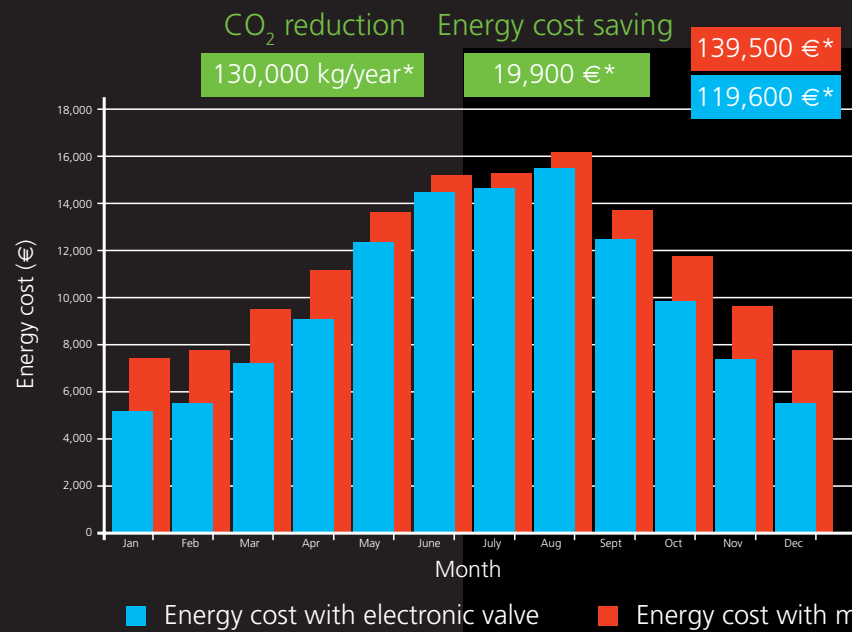

* Measurements made in a telephone exchange cooled by 6 chillers R22 bi-circuit with maximum capacity 900kW

Energy cost saving
14.3 %*

Refrigeration Case Study

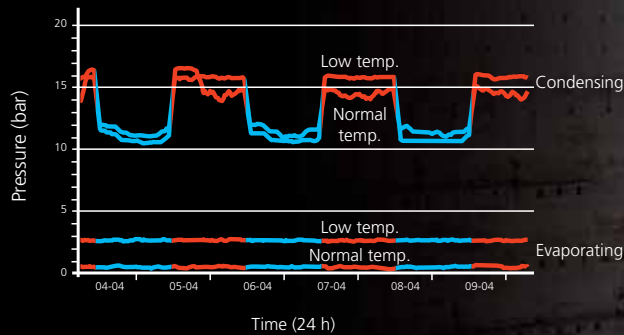
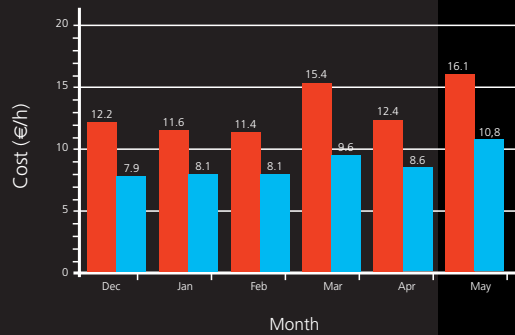

■ Operation with electronic valve ■ Operation with mechanical valve

Energy cost saving
25 %

"...using electronic valves at the supermarket in question gives rise to an average saving... between 20% and 35%..."

from: "Energetic performance of different expansion valves in a supermarket", CNR (National Research Council) IIR Conferences in Vicenza 2005



CAREL:

- Founded in 1973, thirty years' experience in electronic control for refrigeration and air-conditioning.
- Over 700 employees, 5 production sites worldwide, 7 subsidiaries, direct operations in 12 countries and distributors in 75.
- 7% of consolidated sales invested and 20% of staff directly employed in Research and Development.

Headquarters

CAREL S.p.A.
Via dell'Industria, 11 - 35020 Brugine - Padova (Italy)
Tel. (+39) 0499 716611 - Fax (+39) 0499 716600
carel@carel.com - www.carel.com

Subsidiaries

CAREL Australia Pty Ltd
www.carel.com.au
sales@carel.com.au

CAREL China Ltd.
www.carelhk.com
info@carelhk.com

CAREL Deutschland GmbH
www.carel.de
info@carel.de

CAREL Export
www.carel.com
carelexport@carel.com

CAREL France Sas
www.carelfrence.fr
carelfrence@carelfrence.fr

CAREL Italia
www.carel.com
carelitalia@carel.com

CAREL Sud America Ltda.
www.carel.com.br
carelsudamerica@carel.com.br

CAREL U.K. Ltd.
www.careluk.co.uk
careluk@careluk.co.uk

CAREL USA L.L.C.
www.carelusa.com
sales@carelusa.com

Affiliated Companies:

CAREL Korea Co. Ltd.
www.carel.co.kr
info@carel.co.kr

CAREL (Thailand) Co. Ltd.
www.carel.co.th
info@carel.co.th